

GX8002 Condensate removal pump set → HR10 – HR120
Condensaat afvoerpomp set → HR10 – HR120

- 1x Condensate removal pump
Condensaat afvoerpomp
Art. nr. IX8002



- 1x Vinyl hose Ø10/13mm - Length 6 meter
PVC slang Ø10/13mm – Lengte 6 meter
Art.nr. IK5786

- 1x Hose to Hose adapter 2x Ø10mm
Slangkoppeling 2x Ø10mm
Art. nr. IX5463



- 1x Hose to waste/soil pipe
Aansluiting Slang Ø10mm op
Riool afvoerbuis
Art. nr. IX5464



- 1x Rubber adapter Ø21 – Ø40mm
Art. nr. IX5461



Optional / Optioneel:

- Vinyl hose Ø10/13mm - Length 30 meter
PVC slang Ø10/13mm – Lengte 30 meter
Art.nr. IK5785



Installation manual

- See manual Condensate removal pump
- Specific instructions HR10- HR120
- Zie Handleiding Condensaat afvoerpomp
- Specifieke instructies HR10 – HR12

Specific Instructions HR10 – HR120
Specifieke Instructies HR10 – HR120

- Hi level safety switch
- Hoogniveau veiligheidsschakelaar
Max. 3A, Normally Closed

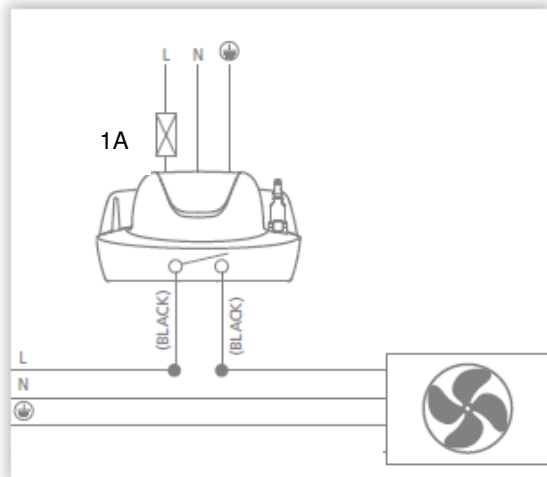

HR10 - HR60
 < 3A

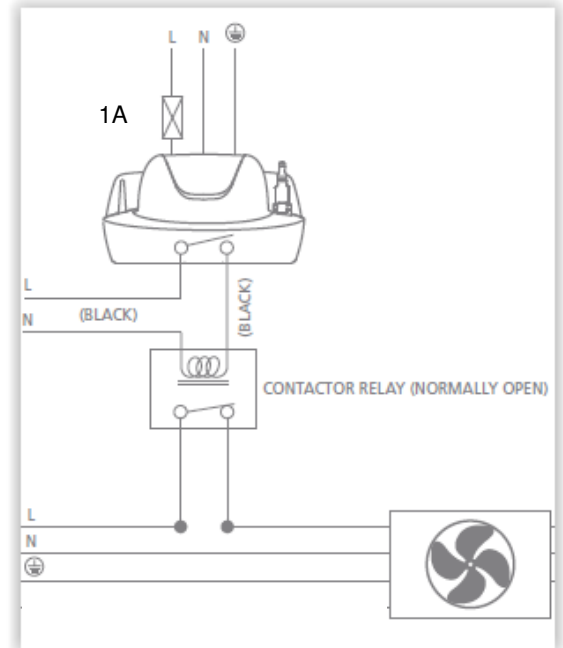

HR80 – HR120
 > 3A

➔ Relay necessary
 Relais noodzakelijk

- Hose to waste/soil pipe

- Aansluiting slang Ø10mm op riool afvoerbuīs



- Rubber adapter Ø21 – Ø40mm
 To connect Ø40mm siphon connection to the tank of the pump.

T.b.v. aansluiting Ø40mm sifon naar de tank van de pomp.

